

Korry MSC knobs no. 486

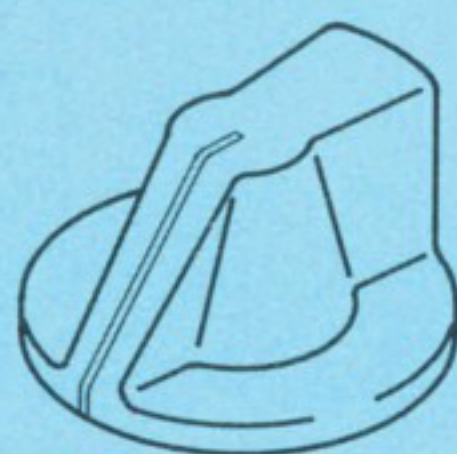

MSC486-A1B2

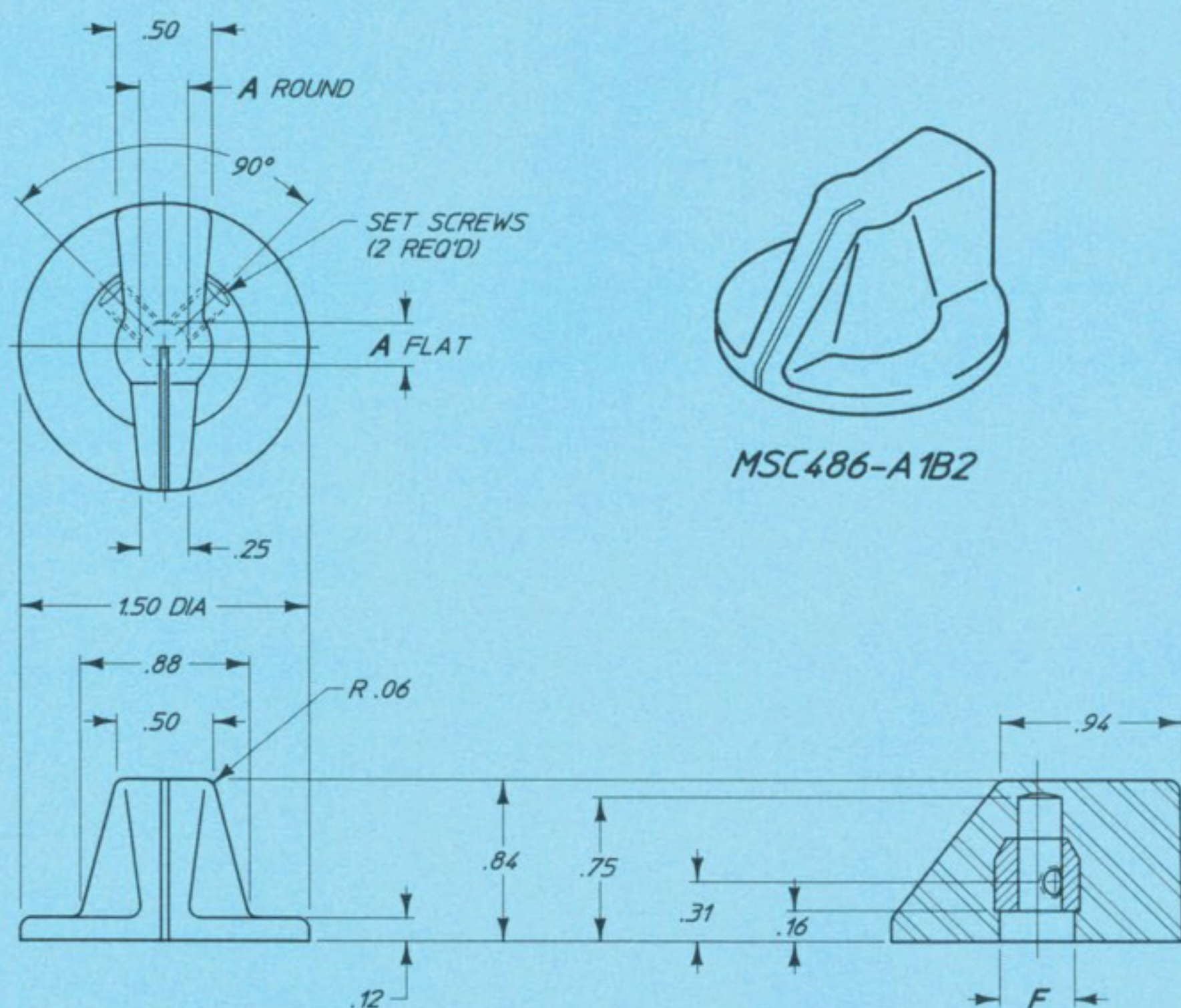
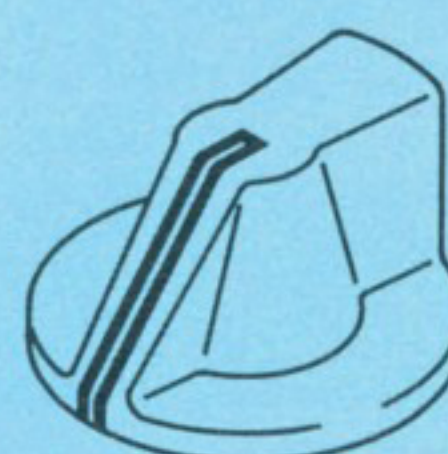

MSC486-A1G2



MSC 486

MSC 486

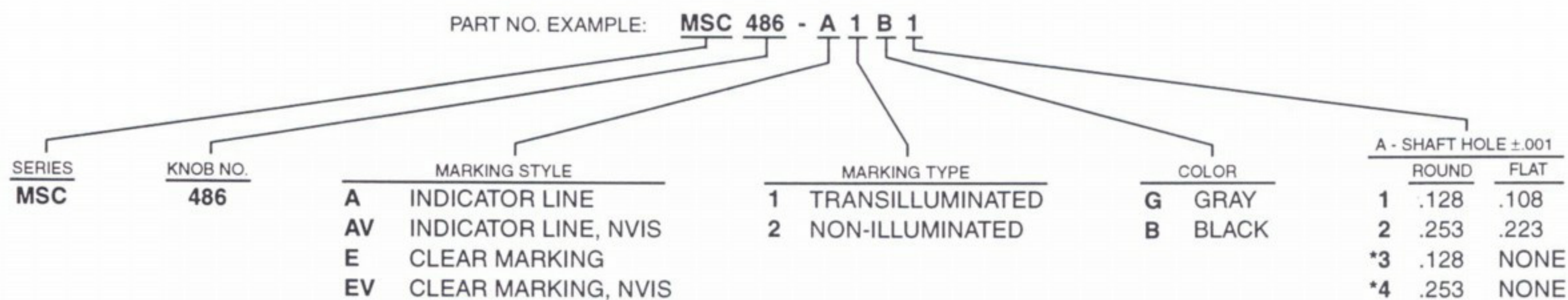

KNOB NO.	BRIGHTNESS RATIO ±25%	SET SCREWS		F - C'BORE DIA.		MAX. WT. OZ.
		SHAFT HOLE SIZE		SHAFT HOLE SIZE		
		1/8	1/4	1/8	1/4	
486	†	MS51021-103	MS51021-132	.260	.385	0.54

SPECIFICATIONS:

- Material: Thermoplastic molding compound, clear for transilluminated knobs and colored for non-illuminated knobs. Insert is brass per QQ-B-626 (or equivalent).
- Shaft hole diameters conform to MS33743 (except for 3/16 size) to accommodate control shaft diameters conforming to MS33742.
- Finish: Knob, black color no. 37038; gray color no. 36231 per Federal Standard 595. White color no. 37875 per Federal Standard 595 except reflectance may be reduced to 50% minimum. All white markings on gray knobs are surrounded by a black border as shown. Insert is nickel plated per QQ-N-290.
- The daylight contrast of our knobs meets a value of 9 minimum. Contrast (C) is defined as:

$$C = \frac{B_2 - B_1}{B_1}$$

Where B_1 is the average brightness of the black border or background and B_2 is the average brightness of the marking.

- The brightness ratio shown on our drawings is the ratio of average brightness of the illuminated marking on the knob to the average brightness of a standard light source which simulates the knob lighting aperture of an edge lighted panel and is expressed as a decimal. This information may be used by the designer to establish the brightness of the knob lighting apertures of the edge lighted panel.
- † Brightness ratios are omitted from this catalog due to lack of complete data on all listed dash numbers. Document control drawings will include the brightness ratios, as required.
- Brightness ratio does not include markings within .25 radius of center of knob. Brightness values do not apply to non-illuminated knobs.
- Unless otherwise specified, tolerance is ± .02 inch for two place decimal dimensions ± .010 inch for three place decimal dimensions and ±2° for angles.
- Knobs with round shaft holes are not recommended for aircraft applications.